

Fully Automatic Bottle Filler & Capper

Bottle your milk with simple efficiency with the help of our Fully Automatic Bottle Filler & Capper! Place your empty glass or plastic bottle on the conveyor, and the machine will do the rest, perfectly prepping it for the store shelf.

The unique craftsmanship of our machinery, designed for grade A use, and its digital operating screen makes for quick and easy operation. To simplify things further, add an optional product pump and level control. This machine can be operated by just one person, so get ready to amp up for production and your sales!

- Fills glass or plastic bottles
- Compatible with SC2, DBJ screw cap, or Stanpac Snap Caps
- Choice of capper (see next page)
- Removable star wheels to accommodate different bottle sizes
- Adjustable filler bowl to accommodate different bottle heights
- High capacity Fogg fill valve w/ 6 gallon adjustable reservoir
- Lid for storage vat equipped with ports and a vent
- Fills up to 200 gallons or 300 1/2 gallons per hour
- Touchscreen for user-friendly operation
- Cycle counters for tracking production
- Includes infeed and outfeed conveyor
- Stainless steel construction with rounded corners for easy cleaning
- Polycarbonate bottle shield
- Adjustable feet for leveling

Shown with Screw Cap Capper for Plastic and Auto Cycle.



Dimensions	
L	10ft
W	3ft
H	6ft 8in

Screw Cap Capper for Plastic

- Adjustable torque screw cap tightener
- All food-grade plastic
- Easy wash-down design
- Inclined belt cap sorter
- Stainless cap chute with cap level sensor
- Clear polycarbonate conveyor covers
- Adjustable height chute for various bottle sizes
- Cap bin



Stanpac Glass Capper

- Automatic cap stomper
- All food-grade plastic
- Easy wash-down design
- Inclined belt cap sorter
- Stainless cap chute with cap level sensor
- Clear polycarbonate conveyor covers
- Adjustable height chute for various bottle sizes
- Cap bin



Snap Cap Capper for Plastic

- Automatic cap stomper
- All food-grade plastic
- Easy wash-down design
- Spinner cap sorter design
- Stainless cap chute
- Adjustable height chute for various bottle sizes
- Cap bin



CAPPER

CHOOSE BOTTLE SIZE TEMPLATES MADE TO FIT

Various sized star wheels, guides & lifters



Fogg filler valve spacer rings and extra O-rings



TEMPLATE

Fully Automatic Bottle Filler & Capper in operation



Custom Conveyors

Any length you need!



OPTIONS

Semi-Automatic Bottle Filler & Capper

Get ready to bottle more milk with our **Semi-Automatic Bottle Filler & Capper** equipment! The unique craftsmanship of this machine makes both operating and cleaning a breeze. Designed for grade A use, this machine works with both glass and plastic bottles.

Add on the optional product pump, level control and Auto Cycle options with a sleek, clean digital operating screen. Perfect for low volume product runs. This process can be overseen by just one person, but to maximize efficiency, it works best with two. Get ready to crank out the milk and crank up your sales today!

Shown with Screw Cap Capper for Plastic and Auto Cycle and Semi Auto Cycle option.



- Fills glass or plastic bottles
- Compatible with SC2, DBJ screw cap, or Stanpac Snap Caps
- Choice of capper (see next page)
- Removable template to accommodate different sized bottles
- Adjustable filler bowl to accommodate different height bottles
- High capacity Fog fill valve
- Lid for storage vat equipped with ports and a vent
- Fills up to 200 gallons or 300 1/2 gallons per hour
- Stainless steel construction with rounded corners for easy cleaning
- Polycarbonate bottle shield
- Counterbalanced manual foot pedal or Auto Cycle
- Adjustable feet for leveling
- Caster option



Castors available

Dimensions

L	5 ft
W	2 ft
H	7 ft

SCREW Screw Cap Capper for Plastic

- Adjustable torque screw cap tightener
- All food-grade plastic
- Easy wash-down design
- Inclined belt cap sorter
- Stainless cap chute with cap level sensor
- Clear polycarbonate conveyor covers
- Adjustable height chute for various bottle sizes
- Cap bin

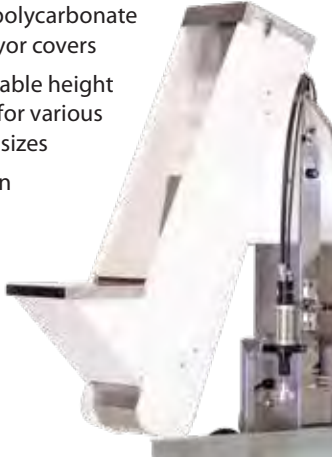

GLASS Glass Stanpac Capper

- Automatic cap stomper
- All food-grade plastic
- Easy wash-down design
- Inclined belt cap sorter
- Stainless cap chute with cap level sensor
- Clear polycarbonate conveyor covers
- Adjustable height chute for various bottle sizes
- Cap bin



SNAP Snap Cap Capper for Plastic

- Automatic cap stomper
- All food-grade plastic
- Easy wash-down design
- Spinner cap sorter design
- Stainless cap chute
- Adjustable height chute for various bottle sizes
- Cap bin



CAPPER

Bottle Template Trays & Pushers

- Heavy gauge stainless steel
- Adjustable
- Quick change
- Easy to clean



A Bottle Pusher for templates C, D & H



B Bottle Pusher for templates E, F, G & I



Template C for tall quart



Template D for round pint

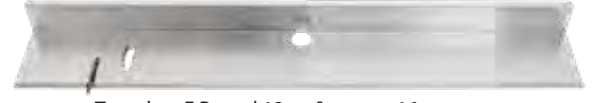

Template E Round 12 oz & square 16 oz



Template F StanPac glass half gallon



Template G StanPac glass quart & squat pint



Template A for plastic gallons



Template B for plastic half gallon & squat quart

TEMPLATE

STANDARD

Manual Foot Pedal Setup

Cost effective, low-maintenance setup for your bottler! Comes standard.

- Counterbalanced manual foot pedal
- No air supply required
- Simple operation



(rear view)



Semi Auto Cycle

Easier and less strenuous on your bottler operator compared to the manual version!

- Automated foot pedal
- Manual & auto modes
- Automated capper
- Job cycle counters for tracking production
- Requires air supply 90 psi
- Timed fill time



(rear view)



OPTIONS

Swivel Caster Option

Swivel casters make machine transporting easy!



4070 unit



4060 unit





Milk Pump Assembly

This product pump boasts premium stainless steel as well as a 1HP Tech Top Motor and a Ben Anderson Style Milk Pump with a 4 blade impeller. Built to handle high-pressure wash-downs, this versatile pump just might make your life a whole lot easier. This pump is ready to plug in and transfer milk from tank to pasteurizer or tank to tank. You can expect up to 50 GPM depending on total milk solids.

- 1 HP
- 110V, 60Hz, single phase
- 50 GPM
- Stainless steel
- Wash-down capable

Control Box Vari-speed



- 110V, 60Hz, Single phase power source
- 220 3-phase output
- Heavy duty plastic box construction
- Dual selector switch for probe level controller or manual operation
- 1 HP frequency drive

PIPE KIT

- Basic SS Piping and Check Valve for Pump System Connection to Fillers



Level Controller



- SS probe
- Stainless level adjustment bracket



Pump

- Ben Anderson milk pump
- 1HP Tech top wash-down motor
- Available in 110 single phase or 220 3-phase for frequency drive box
- 4 blade impeller style

**Don's
DAIRY SUPPLY^{INC}**



349 ROSES BROOK
SOUTH KORTRIGHT, NY 13842

Price List

Single Valve Filler Base Model:

For Plastic Snap Cap- \$ 11,625.00

For Plastic Screw Cap- \$ 17,187.50

For Stanpac Glass Cap- \$14,687.50

Template (each)- \$318.50

Pusher (each)- \$162.50

Upgrade to Semi-Auto Touchscreen \$ 4,950.00

Fully Automatic Single Valve Filler

For Plastic Snap Cap- \$ 34,687.50

For Plastic Screw Cap- \$ 39,500.00

For Stanpac Glass Cap- \$ 36,562.50

Set of Star Wheels (each size)- \$ 468.00

Pump Kit w/ Variable Speed Drive- \$ 3975.00

Float- \$ 255.00